



OLIVER TECHNOLOGIES, INC.
FHA FOUNDATION BRACING SYSTEM

INTRODUCTION

The All Steel foundation 1100 "V" series is designed to resist both longitudinal and lateral wind loads, replacing all frame anchors. Where noted, the IC "V" indicates concrete, wet or dry full system; both transverse and longitudinal bracket.(A) or the combination: concrete wet or dry transverse (D) and longitudinal brackets (J). These drawings show foundation details which are applicable to FMHCSS (HUD Code) Wind Zone 1 houses, manufactured homes, or mobile homes only, and when installed accordingly, will meet or exceed the permanent foundation requirements of Section 100-1.C of the HUD/FHA Permanent Foundations Guide for Manufactured Housing. The foundation plan shown is general and is to be adjusted to meet the specific house being installed. These design drawings are supplemental to the home installation manual. All other home manufacturers instructions for installation of stabilizing devices must be followed, including installation of sidewall vertical tie-down anchors, and mating line concrete, shearwall or center-line tie-down anchors. Pier spacing shall be based on soil conditions and roof loads for the site.

GENERAL NOTES

1. Pier(s) and footing(s) shall be located per home manufacturers installation instructions. Support piers other than the "V" brace shall be in accordance with the home manufacturers installation instructions and shall be of designs approved by the home manufacturer. Each Oliver system may replace one (1) required pier.
2. FOUNDATION BRACE SYSTEM shall be Oliver Technologies Inc. (OTI) All Steel Foundation System Model 1100 IC "V". Concrete footer for the system shall be a minimum 24" X 24" X 8", 2500 psi concrete, and may be un-reinforced.
3. FOUNDATION BRACE SYSTEM shall be installed in accordance with OTI installation instructions and this foundation plan using components as specified on this plan.
4. The number of FOUNDATION BRACE SYSTEM shall be as specified in Table 1, located on sheet 2 of 2, unless different requirements are specified by the engineer of record based on house design or site conditions. A minimum of two FOUNDATION BRACE SYSTEMS are required on any home.
5. Vertical tiedown straps, if specified and required by the home manufacturers installation instructions shall be connected to concrete ground anchors using OTI anchors. Strap and anchor shall have a working load capacity of 3150 lbs with a minimum ultimate capacity of 4725 lbs. Strap shall meet ASTM D3953-91. Anchor may be wet application (OTCAW or OTCAWP) or dry application (OTCAD). Strap and anchor shall be installed in accordance with equipment manufacturers instructions.
6. Any special tiedowns specified and required by the home manufacturers installation instructions for shear walls, mating lines, porches or other architectural features shall be installed and connected to concrete ground anchors using OTI anchors per home manufacturers instructions.
7. The base of all footing(s) shall be placed at the maximum frost penetration depth as specified by the Authority Having Jurisdiction.
8. Crawl space access, ventilation and moisture protection to be per the requirements of the Authority Having Jurisdiction.
9. Design Criteria:
 FMHCSS (HUD Code) Wind Zone 1, equivalent to 85 mph V3s (3-second gust) per IBC 2006 Table 1609.3.1.
 20 psf Roof Live load minimum.
 40 psf Floor Live Load
 20 psf Structural Total Dead Load
 Seismic Class D per IBC 2006
 Soil Allowable Bearing 1000 psf minimum (design spacing shows 1500 psf)
 Not to be sited within 1500 feet of the coast line (per WZ 1 home construction)
 Maximum Pier Height (top of footing to bottom of home main frame members) not to exceed 48 inches.

THIS FOUNDATION IS SUITABLE FOR THE SITE AND SOIL CONDITIONS SPECIFICALLY STATED HEREIN. SITE EVALUATION BY A DESIGN PROFESSIONAL, OR BY THE AUTHORITY HAVING JURISDICTION, IS RECOMMENDED. DESIGN REVISIONS BASED ON SPECIFIC SITE CONDITIONS SHALL BE BY A REGISTERED DESIGN PROFESSIONAL ACCEPTABLE TO THE LENDER AND/OR THE AUTHORITY HAVING JURISDICTION. ALTERNATE DEVICES MAY BE SUBSTITUTED WITH ENGINEER APPROVAL.

CALL OUT	NAME	PART NO.	MATERIAL	FINISH	COMMENT
A(D)	CONCRETE FULL SYSTEM DRY SET CONNECTOR BRACKET	1101CVD	CONCRETE ASTM A-36	HOT DIPPED OR COATED ZINC GALVANIZED	5/8" X 3" SLEEVE CONCRETE ANCHORS, 2 REQUIRED CARRIAGE BOLT & HEX NUT, GRADE 5, 2 REQUIRED
A(W)	CONCRETE FULL SYSTEM WET SET ANCHOR BRACKET	1101CVW	CONCRETE ASTM A-36	HOT DIPPED OR COATED ZINC GALVANIZED	CARRIAGE BOLT & HEX NUT, GRADE 5, 2 REQUIRED SEE INSTALLATION USING CONCRETE RUNNER ETC.
C	CONCRETE BASE	1100-W-TACA	CONCRETE		CARRIAGE BOLT & HEX NUT, GRADE 5, 1 REQUIRED
D(W)	CONCRETE WET SET TRANSVERSE ANCHOR U BRACKET	1100-D-TACA	CONCRETE		CARRIAGE BOLT & HEX NUT, GRADE 5, 1 REQUIRED
D(D)	CONCRETE DRY SET TRANSVERSE CONNECTOR U BRACKET	1100-D-TACA	CONCRETE		CARRIAGE BOLT & HEX NUT, GRADE 5, 1 REQUIRED
E	"V" BRACE 1 1/2" SQ. TUBE 20' LONG	1.50-20-P	ASTM #A513	RUST RESISTANT BLACK PAINT	
	"V" BRACE 1 1/2" SQ. TUBE 28' LONG	1.50-28-P	ASTM #A513	RUST RESISTANT BLACK PAINT	
	"V" BRACE 1 1/2" SQ. TUBE 39' LONG	1.50-39-P	ASTM #A513	RUST RESISTANT BLACK PAINT	
	"V" BRACE 1 1/2" SQ. TUBE 44' LONG	1.50-44-P	ASTM #A513	RUST RESISTANT BLACK PAINT	
	"V" BRACE 1 1/2" SQ. TUBE 54' LONG	1.50-54-P	ASTM #A513	RUST RESISTANT BLACK PAINT	
F	"V" BRACE I-BEAM CONNECTOR	1100-10-P	ASTM #A36	RUST RESISTANT BLACK PAINT	
H	TELES. TRANSVERSE ARM 1 1/2" SQ. TUBE 60" LONG	1.50-60-P	ASTM #A513	RUST RESISTANT BLACK PAINT	
	TELES. TRANSVERSE ARM 1 1/2" SQ. TUBE 72" LONG	1.50-72-P	ASTM #A513	RUST RESISTANT BLACK PAINT	
	TELES. TRANSVERSE ARM 1 1/4" SQ. TUBE 60" LONG	1.25-60-P	ASTM #A513	RUST RESISTANT BLACK PAINT	
	TELES. TRANSVERSE ARM 1 1/4" SQ. TUBE 72" LONG	1.25-72-P	ASTM #A513	RUST RESISTANT BLACK PAINT	
I	TRANSVERSE ARM I-BEAM CONNECTOR 2 PIECES	1100-9-P	ASTM #A36	RUST RESISTANT BLACK PAINT	
J(W)	CONCRETE WET "V" ANCHOR BRACKET	1100-W-CPCA	CONCRETE ASTM #A-36	RUST RESISTANT BLACK PAINT	CARRIAGE BOLT & HEX NUT, GRADE 5, 2 REQUIRED CARRIAGE BOLT & HEX NUT, GRADE 5, 1 REQUIRED
J(D)	CONCRETE DRY "V" ANCHOR BRACKET	1100-D-CPCA	CONCRETE ASTM #A-36	RUST RESISTANT BLACK PAINT	CARRIAGE BOLT & HEX NUT, GRADE 5, 1 REQUIRED

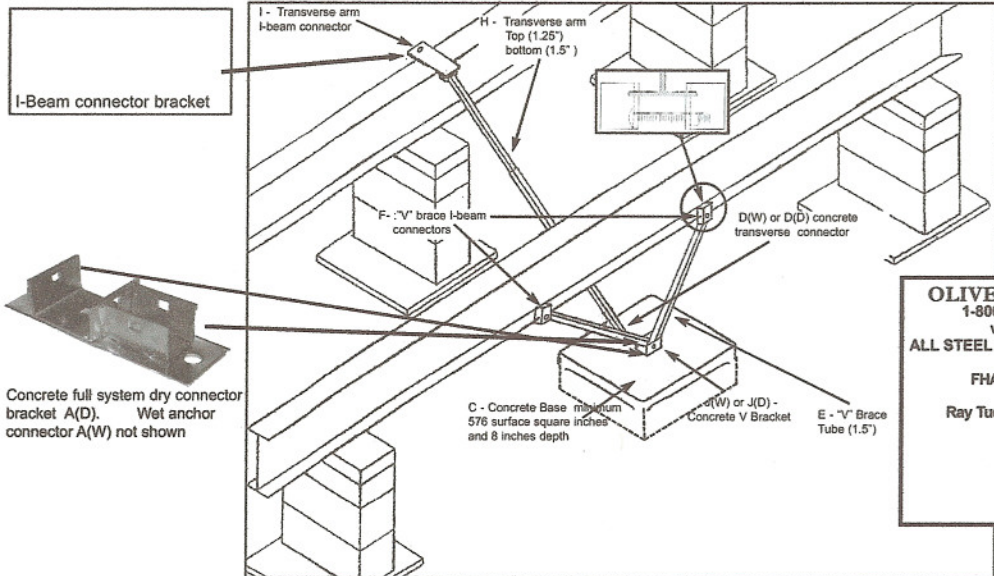

The adjustable outrigger is recommended to be used for door and window support where load ratings do not exceed 1700 lbs.

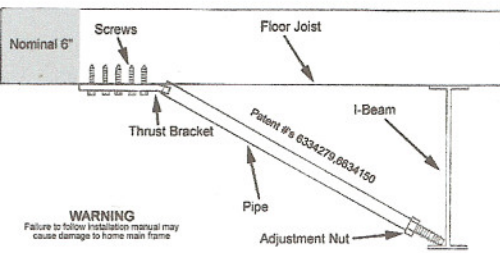

SKIRTING OR NON-LOAD BEARING WALL ENCLOSURES.

EXAMPLES ONLY:
 BRICK OR BLOCKED WALL, HARDIE PANEL SIDING, VINYL OR INSULATED VINYL SIDING, OR WOOD FRAMED WALL USING PRESSURE TREATED 2x4-SPF #3 OR BETTER AT 16" ON CENTER (O.C.), PRESSURE TREATED PLYWOOD SHEETING FASTENED WITH 8 GAUGE GALVANIZED NAILS IN EDGES AND 1/4 FIELD TREATED PLATE, FASTENED TO FOOTING USING CONCRETE NAILS AT 12" O.C. OR POWERSHOT CONCRETE FASTENERS AT 2' O.C.

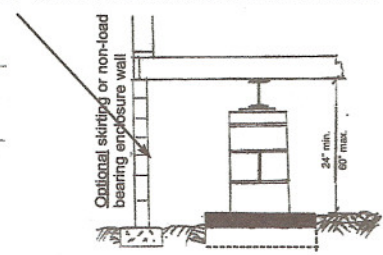

OLIVER TECHNOLOGIES, INC.
 1-800-284-7437 fax: 931-796-8811
 www.olivertechnologies.com
ALL STEEL FOUNDATION SYSTEM MODEL 1100 IC "V"
FHA FOUNDATION BRACE SYSTEM
 Ray Tucker, P.E. ~ Consulting Civil Engineer
 2117 W. 25th Street #1
 San Pedro, CA 90732
 Design Date: Aug. 21, 2007
 Scale: None
 Page-Sheet: 1/2 ~

ENGINEER APPROVAL
 NOV 28 2007
 STATE OF TEXAS
 R. F. TUCKER
 50450
 REGISTERED PROFESSIONAL ENGINEER
 Oliver Technologies, Inc.
 PO Box 9,
 467 Swan Ave. ~ Hohenwald, TN 38462



OLIVER TECHNOLOGIES, INC.
FHA FOUNDATION BRACING SYSTEM INSTALLATION INSTRUCTIONS

SPECIAL CIRCUMSTANCES

If the following conditions occur - STOP! Contact Oliver Technologies at 1-800-284-7437 for further instruction.

- a) System height exceeds 48 inches b) Roof eaves exceed 24 inches c) Sidewall height exceeds 102 inches d) Roof pitch greater than 7/12 e) Footing to surface area exceeds 4 square feet f) Soil conditions less than 1000 psf g) Main rail spacing exceeds 102 inches

INSTALLATION USING CONCRETE RUNNER/FOOTER (IC"V")

The concrete runner or slab may be any shape that has the minimum of 2900 cu. in. with a minimum slab depth of 3 1/2 inches (dry set) or 6" (wet set) at the system location. The surface of a concrete footing must be large enough to support the pier load and allow at least 4" from the concrete bolt to the edge of the footer (example 24"X24"X6"). The concrete shall be a minimum 2500 psi mix (pre-blended sacked concrete mix is acceptable.) Special inspection of the anchor installations is not required. When Single Section homes are installed on runners or full slab and adjoining piers are permanently fixed, no diagonal frame anchors needed. If the 1100 ITC transverse system only (D bracket) needs to be installed without using the 1100 ILC longitudinal system (J bracket), it must be installed within 18" of adjoining pier.

LONGITUDINAL: (a) When using the 1100 wet set J(W) bracket, center directly below the main rail at desired pier location and secure for pour. (b) When installing in cured concrete, use the 1100 dry set J(D) bracket. The dry set bracket is attached to the concrete using two (2) 1/2" X 3" concrete wedge bolts. Place the bracket at desired pier location, mark hole locations, using a 1/2" diameter masonry bit, drill a 3" minimum depth hole. Make sure all concrete dust and debris are blown from holes. Place wedge bolts into drilled holes, place 1100 J(D) bracket onto wedge bolts and start wedge bolt nuts. Slightly drive wedge bolts down by hitting the nut (use wood to cushion top bolt threads). The sleeve of the concrete wedge bolt needs to be at or below the top of concrete. Complete by tightening nuts.

LATERAL: (a) For wet set installation set the transverse anchor bracket D(W) into runner/footer at the desired location, preferably directly in front of the longitudinal bracket or within 18" of proposed pier location - pointed towards the opposing I-Beam. Secure for pour. (b) For dry set installation the dry set bracket D(D) is attached to the cured concrete using two (2) 1/2" X 3" concrete wedge bolts at same locations noted in (a) above. Mark bolt hole locations using a 1/2" diameter masonry bit, drill a minimum 3" depth holes, clear all dust and debris from holes. Set wedge bolts. Attach the transverse connector bracket. If needed, lightly drive wedge bolts down by hitting the nut (use wood to cushion top bolt threads). The sleeve of the concrete wedge bolt needs to be at or below the top of concrete. Complete by tightening nuts.

COMPLETE SYSTEM BRACKET INSTALLATION:

When using the 1100 wet set anchor bracket A(W) or dry set connector A(D), align the bracket perpendicular to the I-Beam with the longitudinal connector centered directly below and the lateral (transverse) connection pointed inward towards the opposing I-Beam. When installing the dry connector bracket A(D), mark the hole locations. Using a 5/8" diameter masonry bit drill two holes a minimum of 3", clear holes and set two (2) 5/8"X3" sleeve wedge bolts. Attach the complete connector bracket A(D) then lightly tap the concrete bolts down making sure the sleeves are flush with the concrete. Complete by tightening the nuts.

SPECIAL NOTE: The longitudinal "V" brace system serves as a pier under the home and should be loaded as any other pier. It is recommended that after leveling piers, and one-quarter (1/4") inch before home is lowered completely onto piers, complete items 1 through 5 below.

INSTALLATION OF LONGITUDINAL "V" BRACE SYSTEM

- Select the correct square tube brace (E) length for set-up (pier) height at support location.

PIER HEIGHT (APPROX. 40-60 DEGREES MAX)	TUBE LENGTH 1.50"
14" to 18"	20"
18" to 25"	28"
24" to 35"	39"
30" to 40"	44"
36" to 48"	54"

Pier Height =
the dimension from the top
of pan/foundation to the bot-
tom of I-beam

- Install both of the 1.50" square tubes (E) into the "U" bracket (J). Inset carriage bolt and leave loose for final adjustment.
- Place I-Beam connectors (F) loosely on the bottom flange of the I-Beam.
- Attach the selected 1.50" tubes (E) to the I-Beam connectors (F) and fasten loosely with bolts and nuts. NOTE: THE ANGLE IS NOT TO EXCEED 60 DEGREES AND NOT BE LESS THAN 40 DEGREES. THE V BRACKET (J) IS STAMPED WITH THE ANGLES TO VERIFY CORRECT DEGREE. Use proper length tube or cut and drill tube to achieve proper length. (The tube may be cut using any appropriate steel cutting method such as steel saw, cutting torch, etc. New holes must be drilled to the dimensions and at the location as shown for part E.)
- Using standard hand tools, tighten all nuts and bolts. When connecting the brace tube to the I-Beam connector bracket (F), tighten at least one and a half to two full turns past hand tight.

INSTALLATION OF THE LATERAL TELESCOPING TRANSVERSE ARM SYSTEM

- Select the correct square tube brace (H) length for set-up lateral(transverse) at support location. The 60" tube length is standard, installing the large (1.50") end as the bottom tube and the small (1.25") tube as the insert, attaching to the I-Beam connector (I). The 72" tube is used on extended frame widths greater than 99.5".
- Install 1.50" (H) to the footer/connector (D) with supplied nut and bolt.
- Slide 1.25" tube into 1.50" and attach I-beam connector (I) with nut and bolt.
- Slide I-Beam connector over top flange of I-beam, secure by attaching frame clip to bottom of connector, using the hole positioned closest to the frame.
- Secure 1.50" and 1.25" transverse arm using four (4) 1/4" X 3/4" self tapping screws in pre-drilled pilot holes of 1.50" arm. Secure all nuts and bolts.

TABLE 1
NUMBER OF FOUNDATION BRACE SYSTEMS REQUIRED
THRU SEISMIC ZONE 4 (SEE DESCRIPTION AT RIGHT)

2 BRACES(A)		3 BRACES(B)		4 BRACES(C)	
WIDTH	HOUSE LENGTH	HOUSE LENGTH	HOUSE LENGTH	HOUSE LENGTH	HOUSE LENGTH
12'	UP TO 76'	-	-	-	-
14'	UP TO 78'	-	-	-	-
16'	UP TO 78'	-	-	-	-
24'	UP TO 78'	-	-	-	-
28'	UP TO 78'	77' TO 86'	-	-	-
32'	UP TO 78'	77' TO 86'	-	-	-
36'	UP TO 62'	63' TO 76'	77' TO 86'	77' TO 86'	77' TO 86'

2 BRACES(A)		3 BRACES(B)		4 BRACES(C)		5 BRACES(D)	
WIDTH	HOUSE LENGTH	HOUSE LENGTH	HOUSE LENGTH	HOUSE LENGTH	HOUSE LENGTH	HOUSE LENGTH	HOUSE LENGTH
12'	-	UP TO 56'	57' TO 80'	57' TO 80'	57' TO 80'	57' TO 80'	TO 86'
14'	-	UP TO 56'	57' TO 80'	57' TO 80'	57' TO 80'	57' TO 80'	TO 86'
16'	-	UP TO 56'	57' TO 80'	57' TO 80'	57' TO 80'	57' TO 80'	TO 86'
24'	-	UP TO 56'	57' TO 80'	57' TO 80'	57' TO 80'	57' TO 80'	TO 86'
28'	-	UP TO 56'	57' TO 80'	57' TO 80'	57' TO 80'	57' TO 80'	TO 86'
32'	-	UP TO 56'	57' TO 80'	57' TO 80'	57' TO 80'	57' TO 80'	TO 86'
36'	-	UP TO 56'	57' TO 76'	57' TO 76'	57' TO 76'	57' TO 76'	77' TO 86'

2 BRACES(A)		3 BRACES(B)		4 BRACES(C)		5 BRACES(D)	
WIDTH	HOUSE LENGTH	HOUSE LENGTH	HOUSE LENGTH	HOUSE LENGTH	HOUSE LENGTH	HOUSE LENGTH	HOUSE LENGTH
24'	-	UP TO 54'	55' TO 72'	55' TO 72'	55' TO 72'	55' TO 72'	73' TO 86'
28'	-	UP TO 54'	55' TO 72'	55' TO 72'	55' TO 72'	55' TO 72'	73' TO 86'
32'	-	UP TO 54'	55' TO 72'	55' TO 72'	55' TO 72'	55' TO 72'	73' TO 86'
36'	-	UP TO 54'	55' TO 72'	55' TO 72'	55' TO 72'	55' TO 72'	73' TO 86'

2 BRACES(A)		3 BRACES(B)		4 BRACES(C)		5 BRACES(D)	
WIDTH	HOUSE LENGTH	HOUSE LENGTH	HOUSE LENGTH	HOUSE LENGTH	HOUSE LENGTH	HOUSE LENGTH	HOUSE LENGTH
24'	-	UP TO 48'	48' TO 68'	48' TO 68'	48' TO 68'	48' TO 68'	69' TO 86'
28'	-	UP TO 48'	48' TO 68'	48' TO 68'	48' TO 68'	48' TO 68'	69' TO 86'
32'	-	UP TO 48'	48' TO 68'	48' TO 68'	48' TO 68'	48' TO 68'	69' TO 86'
36'	-	UP TO 48'	48' TO 68'	48' TO 68'	48' TO 68'	48' TO 68'	69' TO 86'

WHEN REQUIRED BY TABLE 1
 ALL STEEL FOUNDATION BRACE MODEL 1100 IC "V"
 (sample 60" box) PIER/FOOTER SPACING @ 8' O.C. TRANSVERSE ONLY SYSTEM

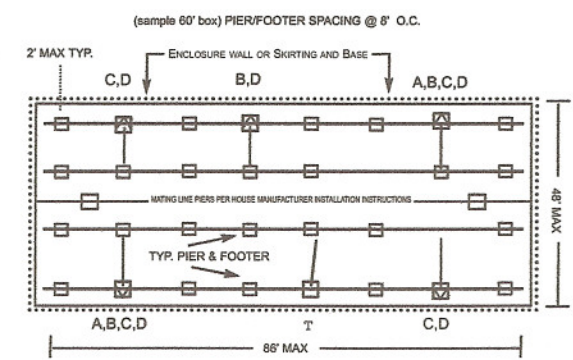
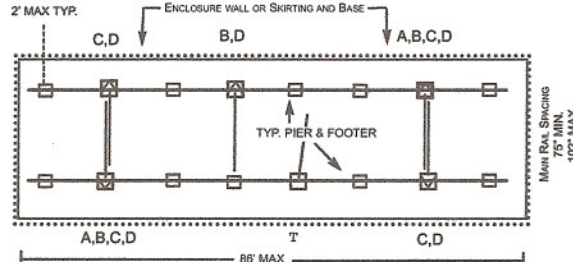

- System Placement:**
- (A) Second pier from end at opposite opposing sides.
 - (B) Same as 'A', add third system placed at center pier, outside rail, either side.
 - (C) Second pier from end, all four sides.
 - (D) Repeat 'C', place 5th system at center pier, outside rail, either side.
 - (T) If eave length exceeds 17" to 24": Use one additional Transverse System

36" MAY BE TRIPLE WIDE UP TO 48" WITH ALL EQUAL FLOOR SECTIONS.
NOTE: MINIMUM OF 4 SYSTEMS REQUIRED FOR SEISMIC RATING.

OLIVER TECHNOLOGIES, INC.
 1-800-284-7437 fax: 931-796-8811
 www.olivertechnologies.com
ALL STEEL FOUNDATION SYSTEM MODEL 1100 IC "V"
FHA FOUNDATION BRACE SYSTEM
 Ray Tucker, P.E. ~ Consulting Civil Engineer
 2117 W. 25th Street #1
 San Pedro, CA 90732
 Design Date: Aug. 21, 2007
 Scale: None
 Page-Sheet: 2/2 ~

ENGINEER APPROVAL

STATE OF TEXAS

R. F. TUCKER

60450

REGISTERED PROFESSIONAL ENGINEER

NOV 28 2007

Oliver Technologies, Inc.
 PO Box 9,
 467 Swan Ave. ~ Hohenwald, TN 38462